

# JSK52 – Heavy Duty Fifth Wheel Coupling 3½" for extreme applications

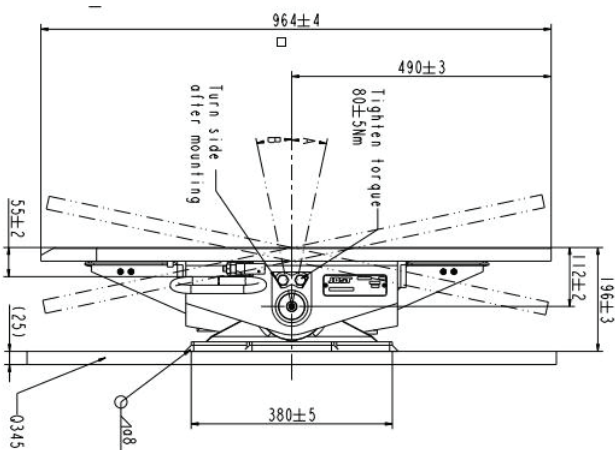
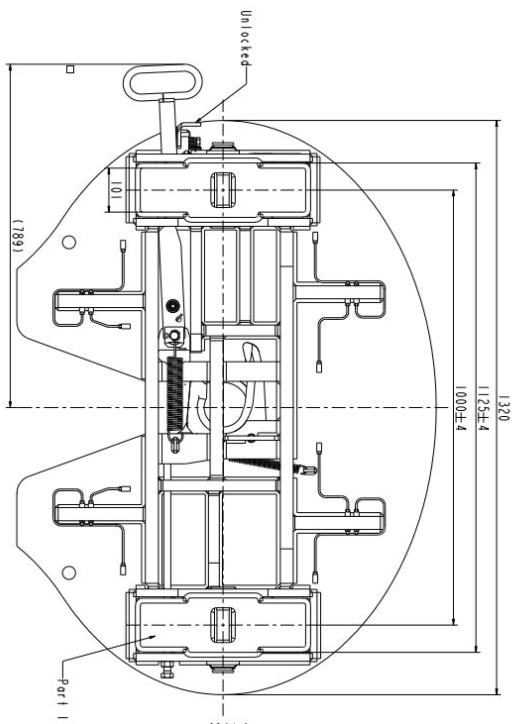

A heavy duty fifth wheel coupling for operation under arduous conditions.

Increased load (up to 75,000kg).

With pivot bearing weld on pedestals.

### Technical specification:

#### Pin and bush

The fifth wheel coupling complies with the directives/standards as per 94/20/EC – Class S, DIN 74084 and ISO 3842. Suitable for 3.5" (90) king pins as per 94/20/EC, DIN 74083 and ISO 4086. Fitted on a mounting plate.

Imposed weight	75,000 kg
D-value	400 kN
Weight	450 kg
Approval Number	CTA-046422

## Spare parts for Type JSK52

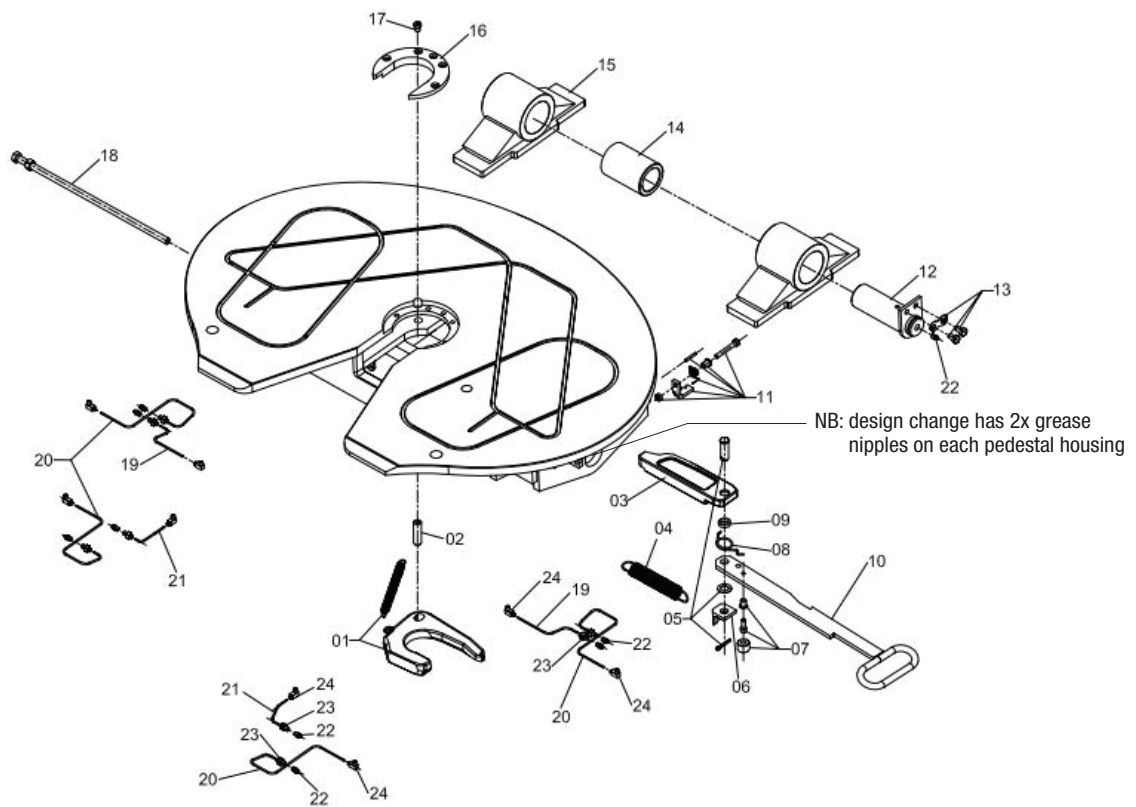

Fig.	Description	Part No.
1	Jaw, complete	SK8301005
2	Lock bolt	SK8301307
3	Locking bar	SK8301209
4	Double tension spring	SK8301210
5	Bar bolt	SK8301006
6	Spring pulling plate	SK8101206
7	Bolt	SK8301007
8	Torsion spring	SK240509
9	Spacer	SK8101305
10	Pull handle	SK8301213
11	Latch mechanism	SK8301008
12	Pivot pin	SK8301205
13	Hex head screw & retaining sheet	000.001.148 & SK3104/046
14	Rubber bushing	SK8301204

Fig.	Description	Part No.
15	Pedestal 196mm	SK8301216
16	Wear ring Socket	SK8301223
17	Head bolt	SK242108
18	Adjusting screw	SK8301301
19	Oil pipe 1	SK8301220
20	Oil pipe 2	SK8301221
21	Oil pipe 3	SK8301222
22	Oil nipple	SK8301308
23	Oil pipe joint	SK8301310
24	90 oil pipe joint	SK8301309