

Important document
Must be handed to the customer before the coupling is mounted!

Mounting

Mounting and operating instructions

Directive 94/20 EC / Appendix I / 5.4 specifies that mounting and operating instructions in the operator's national language must accompany every coupling device.

The vehicle or coachwork manufacturer is responsible for ensuring that the vehicle keeper is supplied with the information needed to operate the coupling devices.

The latest relevant issue of the mounting and operating instructions is the valid edition!

Please find enclosed the mounting and operating instructions

(language as per operator's country)

Operation

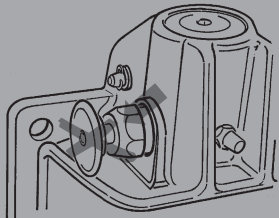
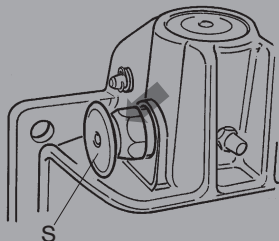

Automatic Trailer Couplings

New article nos.

243A11000 for 243U115EN/X3

also replaces version K/X1 hand lever upwards

243A12000 pour 243 U 115 ES

243B11000 pour 243 U 115 EL/X2

243B12000 pour 243 U 115 EV

Usable with ROCKINGER VARIOBLOC

1. Mounting

1.1 Before fitting

Note: When fitting the coupling, the vehicle manufacturers' relevant specifications must be observed.

1.2 Fitting

The above ROCKINGER automatic trailer couplings are supplied ready to operate.

- Attach coupling with 4 off M10-8.8 DIN 931 hexagon head screws and self-locking nuts of same grade
- Tightening torque **49 Nm**

Note: Bolt heads must be on coupling head side (outer side of crossbar)!

2. Operation

2.1 Hitching

- Withdraw check pin (S) (see drawing)
- Push hand lever upwards
- Release brake on front axle of semitrailer
- Reverse prime mover

Hitching a centre-axle trailer

- Slowly reverse prime mover
- Drawbar eye must mate with centre of funnel.
If not, funnel, drawbar eye and support unit can be damaged.

Check

After every hitching operation it is essential to verify that the coupling is engaged as required by regulations.

The check pin must be flush with its guide bush after hitching.

If the check pin protrudes from its guide bush (this can also be established by touch if dark), this indicates that hitching has not been carried out correctly (see drawing), and that you are at **risk of an accident**.

The trailer must not be operated in this condition!

2.2 Unhitching

- Withdraw check pin (S)
- Push hand lever upwards
- Separate prime mover and trailer

Member of JOST-World

Maintenance

3. Maintenance

3.1 Care

The normal operational wear and tear of moving parts can be reduced considerably by appropriate care and by regular lubrication of the coupling.

- **Open coupling** (see 2.1) to avoid excessive lubrication of automatic unit
- Lubricate entire coupling via one lubrication nipple (see drawing)
- Close coupling: raise coupling bin with suitable tool
- Where a centre-axle trailer is used, lubricate underside of drawbar and point of contact with coupling

3.2 Inspection

Check wear on the coupling pin using a ROCKINGER reference gauge (order no. 57026) (see drawing).

The diameter of the crowned part may not be less than 36.5 mm.

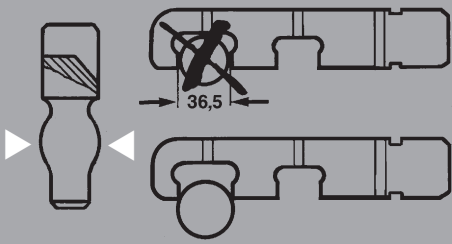

Technical Specifications

Fig: Coupling in fitted position

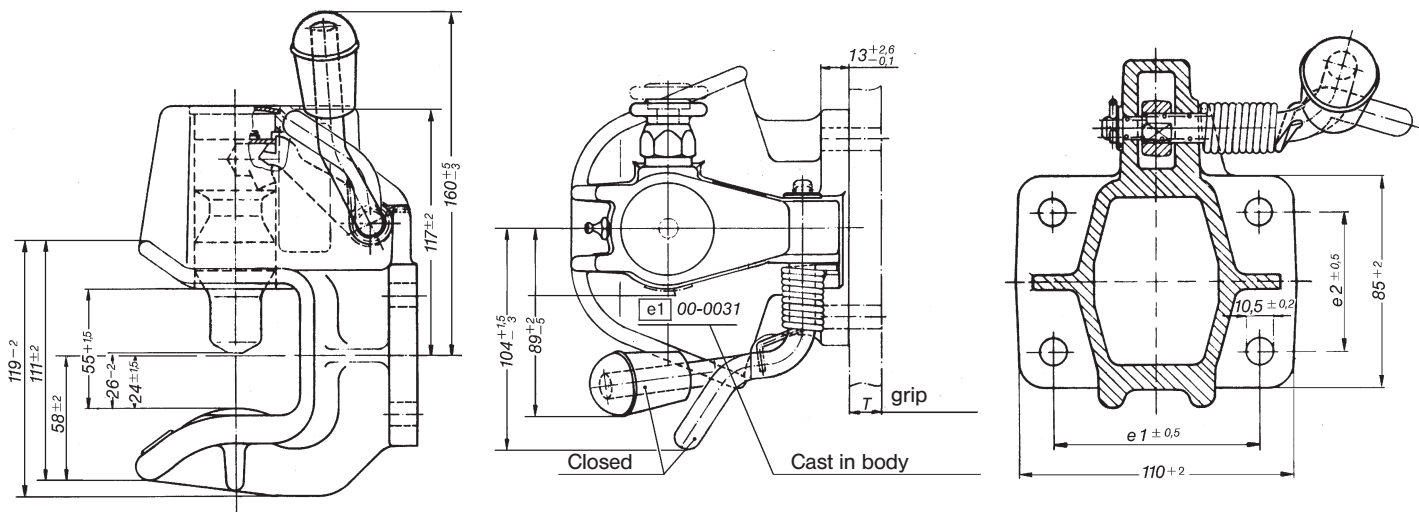

Article no.	Bore pattern (mm) e1xe2	Hand lever	Admissible D-value*1 (kN)	Centre-axle trailer		
				Admissible Dc-value*2 (kN)	Admissible static vertical load (kg)	Admissible drawbar value*3 (kN)
243A11000	83 x 56	diag. upwards	30	18 or 30	250 250	12 8,4
243A12000	85 x 45	diag. upwards	18	18	200	9,6
243B11000	83 x 56	downwards	30	18 or 30	250 250	12 8,4
243B12000	85 x 45	downwards	18	18	200	9,6

*1 D-value for prime mover and semitrailer

$$D \text{ (kN)} = g \cdot \frac{T \cdot R}{T + R}$$

The calculated D-value may be **equal to or less than** the coupling's D-value.

T: total weight of prime mover in t
R: total weight of semitrailer in t
g: acceleration due to gravity 9,81 m/s²

*2 Dc-value for prime mover and centre-axle trailer (only applies in conjunction with drawbar value)

$$Dc \text{ (kN)} = g \cdot \frac{T \cdot C}{T + C}$$

The calculated Dc-value may be **equal to or less than** the coupling's Dc-value.

T: total weight of prime mover in t
C: total weight of centre-axle trailer in t
g: acceleration due to gravity 9,81 m/s²

*3 Drawbar value for centre-axle trailer (only applies in conjunction with Dc-value)

(only applies in conjunction with Dc-value)

$$V \text{ (kN)} = a \cdot \frac{x^2}{l^2} \cdot C$$

The calculated drawbar value may be **equal to or less than** the coupling's drawbar value.

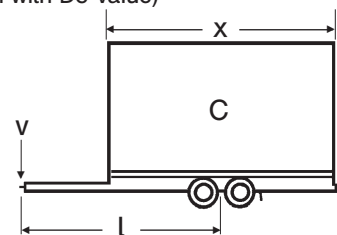

a: comparable acceleration at coupling point in m/s²
a = 1.8 in vehicle with air suspension on rear axle
a = 2.4 in vehicle with other suspension type
l: theoretical drawbar length in m
x: length of load surface in m
x²/l²: **at least 1.0**
C: total weight of centre-axle trailer in t